

Kool Koat[®] ***KOOL KURE***[®]

OVEN & BOOTH SYSTEMS



Distributed by:

Visit our website at www.ColumbiaCoatings.com

**For Technical support or to order replacement parts call
1-931-388-7730**

**1173 Industrial Park Rd
Columbia, TN 38401**

Oven Parts Checklist

QTY	PART #	DESCRIPTION	SIZE
1	BO-1209-F	Door Sill	12 G
1	BO-003	Corner (Vertical Front Right)	12 G
1	BO-002	Corner (Vertical Front Left)	12 G
1	BO-5001	Bottom Channel (Left Front)	12 G
1	BO-5001	Bottom Channel (Right Front)	12 G
2	BO-5010	Top Angle (Left & Right Front)	12 G
2	BO-5007	Top Angle (Left & Right Rear)	12 G
1	BO-5000	Bottom Channel (Left Rear)	12 G
1	BO-5004	Bottom Channel (Right Rear)	12 G
1	BO-5006	Channel (Rear Bottom - Right)	12 G
1	BO-5005	Channel (Rear Bottom - Left)	12 G
2	BO-008	Corner (Vertical Rear)	12 G
1	BO-251	Angle (Top Rear)	12 G
2	BO-1208	Side Panel (Right & Left Front Starter)	16 G
2	BO-1240	Side Panel (Right & Left Rear Ending)	16 G
1	BO-1212	Inside Panel (Right Starter)	16 G
1	BO-1213	Inside Panel (Left Starter)	16 G
1	BO-1241	Inside Panel (Left Ending)	16 G
1	BO-1242	Inside Panel (Right Ending)	16 G
6	BO-1216	Inside Panel (Side)	16 G
1	BO-1268	Inside Panel (w/ burner hole)	16 G
1	BO-1243	Ceiling Panel (Ending)	16 G
4	BO-1218	Ceiling Panel	16 G
6	BO-1207	Side Panel	16 G
1	BO-1269	Side Panel (w/ burner hole)	16 G
1	BO-1349	Side Panel Shaft Hole (Left)	16 G
1	BO-1350	Inside Panel Shaft Hole (Left)	16 G
1	BO-5014	Top Panel (Front Starting)	16 G
1	BO-1220	Ceiling Panel (Starting)	16 G
1	BO-5011	Top Panel (Rear / Ending)	16 G
1	BO-5013	Top Panel (4' Extension)	16 G
3	BO-1223	Inside Panel (Rear)	16 G
1	BO-1224	Inside Panel (Rear Bottom)	16 G
1	BO-5015	Floor Panel (Rear)	10 G
1	BO-5016	Floor Panel (Front)	10 G
1	BO-5018	Floor Panel (Center)	10 G
1	BO-1228	Valance	12 G

Cont'd			
1	BO-1229	Partition Panel (Bottom)	16 G
1	BO-1230	Partition Panel (Center)	16 G
1	BO-1231	Partition Panel (Top)	16 G
2	BO-1261	Air Duct	16 G
2	BO-013	Rear Panel (Right & Left)	16 G
1	BO-263	Panel (Rear, Outside, Center)	16 G
2	BO-0451	Door Channel (Hinge Side)	16 G
2	BO-0450	Door Channel (Latch Side)	16 G
4	BO-680	Door End	16 G
6	BO-029	Backing (hinge mount)	12 G
2	BO-682	Panel (Door Outside)	16 G
2	BO-681	Panel (Door Inside)	16 G
1	BO-135	Striker Mount	3/16"
6	BO-029A	Backing (Hinge Mount)	12 G
1	BO-040	Gusset (Valance)	12 G
12	BO-026	Shim (Hinge 16 G)	16 G
1	BO-1324	Door Stop	16 G
1	BO-1344	Seal Bracket (Right)	12 G
1	BO-1343	Seal Bracket (Left)	12 G
1	BO-1345	Seal Bracket (Top)	12 G
1	BO-0401	Burner Hole Bracket Mounting Plate	16 G
2	BO-681-C	Door Panel (Inside)	
2	BO-682-C	Door Panel (Outside)	
2	BO-1470-2	Rings for Ductwork	
2	BO-5003	Bottom Channel (4' Extension)	

OVEN DIMENSIONS

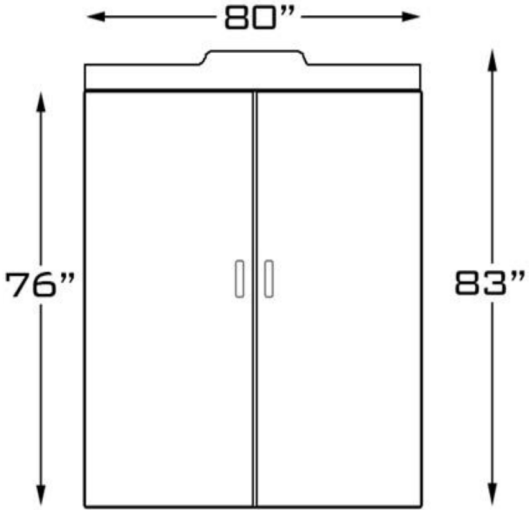

OVEN FRONT

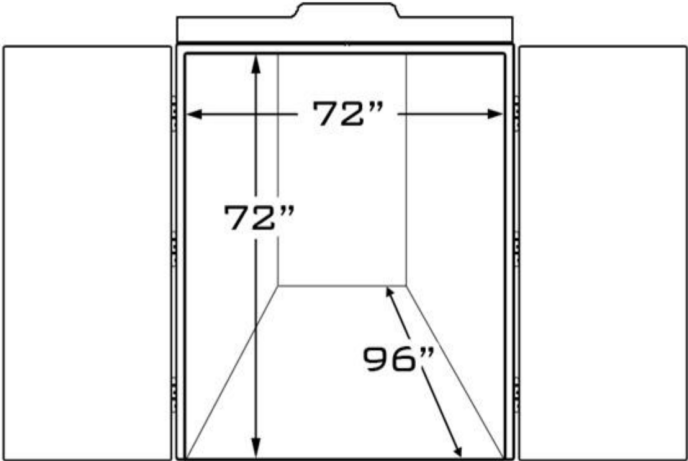

OVEN FRONT
INSIDE

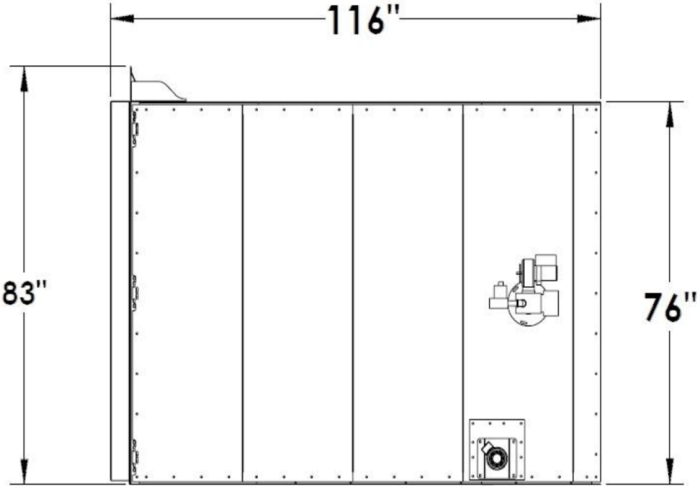

OVEN SIDE

PROGRAMMING THE PID

Display, LED and Key Pad



PV Display: To display the process value or parameter type.





SV Display: To display the set point, parameter operation read value manipulated variable or set value of the parameter.

AT: Auto-tuning LED, flashes when the Auto-tuning operation is ON.

OUT1 / OUT2: Output LED, lights when the output is ON.

ALM: Alarm output LED, lights when one of the alarms is on.

°C, °F: Temperature unit LED. °C: Celsius °F: Fahrenheit

-  **SET** Set Button: Press this key to select the desired function mode and confirm the setting value.
-  **Rotate** Button: Press this key to select parameters within the function mode.
-  **Down** Button: Press this key to decrease values displayed on the SV display. Hold down this key to speed up the decrement.
-  **Up** Button: Press this key to increase values displayed on the SV display. Hold down this key to speed up the increment.

Key Pad Operation

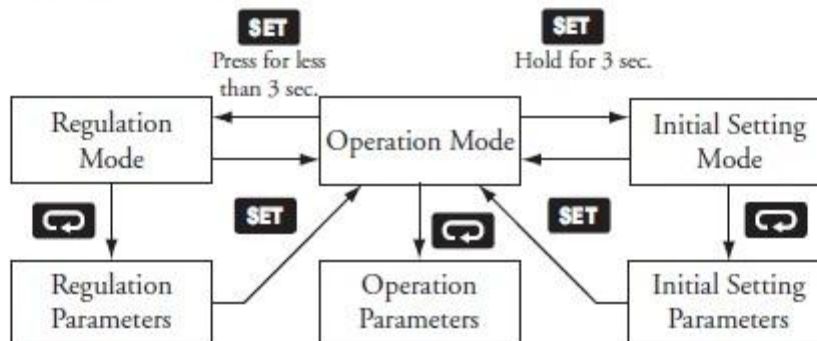







The SOLO temperature controller has three function modes: Initial Setting mode, Operation mode and Regulation mode. When power is first applied to the temperature controller, the module information splash screen appears. This screen shows the firmware version on the PV display and the two output types for that particular model on the SV display. After three seconds, the controller will automatically proceed to the Operation mode main screen. Press and hold the **SET** button for three seconds to go into the Initial Setting mode. Press the **SET** button for less than three seconds to access the Regulation mode. Press the **Rotate** button while inside any of the three function modes to access the individual parameters for each function mode. Use the **Up** and **Down** buttons to change the individual parameter values. Pressing the **SET** button saves the parameter values. Press the **SET** button again to return the controller to the Operation mode.





PROGRAMMING THE PID (continued)

Reset to Factory Default Instructions

All of the following set up instructions are for setting up a controller from the factory defaults. If the application for a controller needs to be changed, reset the controller to factory default using the following steps.





1. Press the  button until the parameter **LoC** appears. Use the  button to select **LoC i**. Press the **SET** button.
2. Press and hold the  and  buttons simultaneously for one second and release.
3. Press the  button repeatedly until the PV display shows **PASS**. Use the  button to change the value on the SV display to **135**. Press the **SET** button.
4. Cycle power on the Controller to reset to factory default mode. All user set values are erased.

Thermocouple or RTD Input

1. Access the Initial Setup mode by pressing and holding the **SET** button for three seconds. In the parameter **INPt**, use the  and  buttons to select the value that corresponds to the thermocouple or RTD type that will be attached to the controller. See the table below for specifications. Press the **SET** button to save the selected value. The controller will display the module information splash screen for three seconds and then return to the main screen.
2. Press the **SET** button for three seconds again. Press the  button to access the **TEMP** parameter. Use the  and  buttons to select either **C** for Centigrade or **F** for Fahrenheit display. Press the **SET** button to save the selected value. The controller will display the module information splash screen for three seconds and then return to the main screen.

Thermocouple* Type and Temperature Range		
Thermocouple J type		-148 ~ 2192°F (-100 ~ 1200°C)

Heating Loop with ON / OFF Control

1. Access the Initial Setup mode by pressing and holding the **SET** button for three seconds. Press the  button until the parameter **Ctrl** appears. Use the  and  buttons to select **onof** for ON / OFF control. Press the **SET** button to save the value. Press the  button to access the parameter **S-HC**. Confirm the default value **HEAT** is selected for controlling a heating loop. Press the **SET** button to return to the controller main screen.

OVEN ASSEMBLY

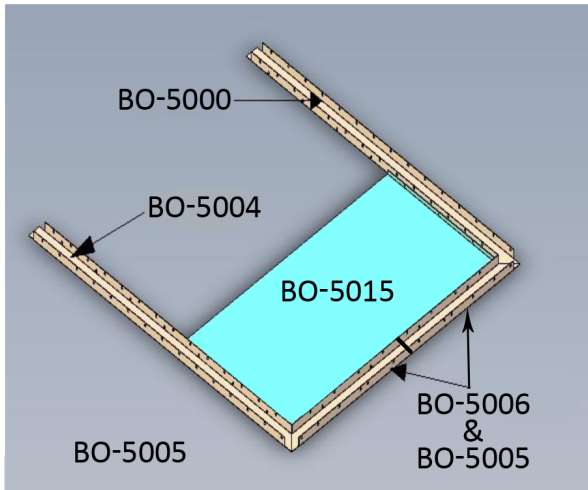

Figure 1

1) Start with laying out parts BO-5000, BO-5004, BO-5005, BO-5006, and BO-5015. Do not bolt parts together yet. *See figure 1.*

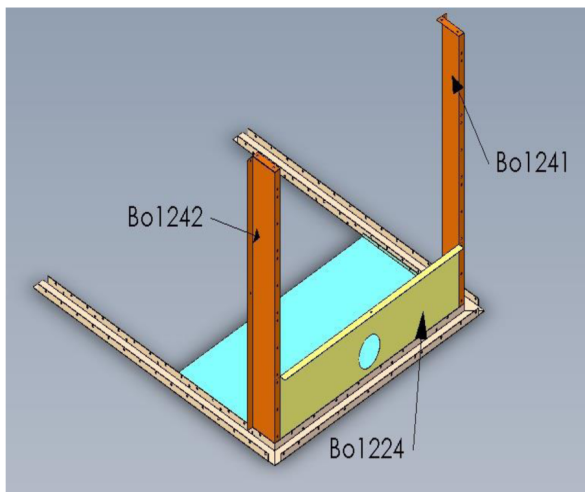

Figure 2

2) Bolt part BO-1241 to BO-5000 using supplied 5/16" bolts. *See figure 2.*

Make sure to not tighten the bolts until other panels are in place.

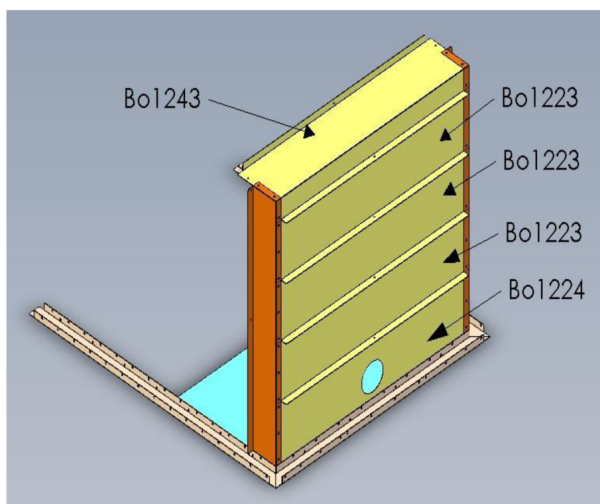

Figure 3

3) Bolt parts BO-5015 and BO-1224 to BO-5006 using 5/16" bolts. Make sure to not completely tighten bolts until other panels are in place.

Bolt BO-1224 to BO-1242 and the BO-1242 to BO-5004. Do not tighten completely.

Bolt parts BO-1223 to BO-1242 and BO-1241. Now bolt all 4 rear panels together using 5/16' bolts and nuts.

Now bolt part BO-1243 to BO-1242 and BO-1241. Now you can tighten all of the bolts.

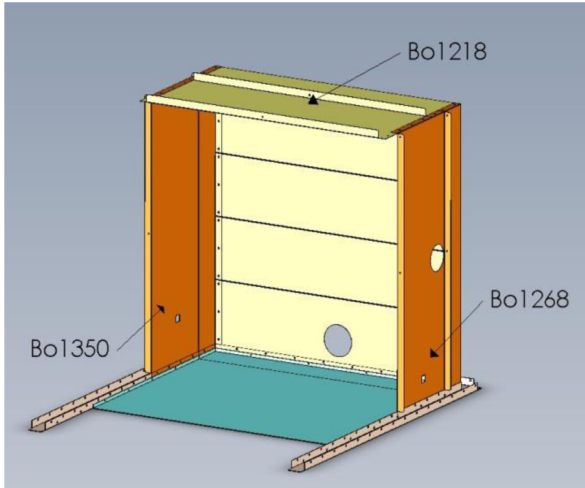

Figure 4

4) Start installing the side and top panels. Start with panels BO-1350, BO-1218 and BO-1268. *See figure 4.*

Once again, make sure not to tighten bolts to allow for adjustments.

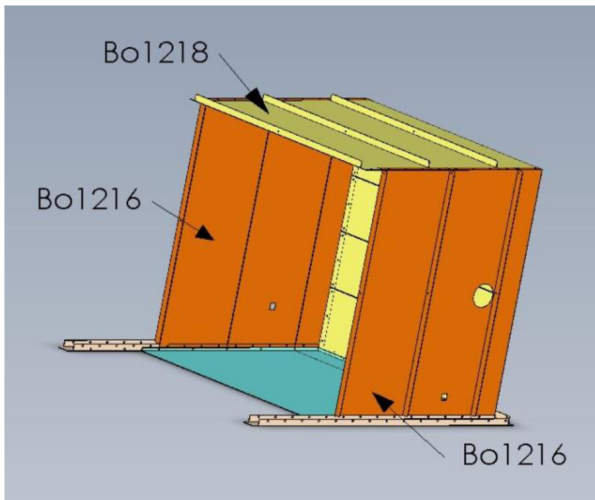

Figure 5

5) Install panels BO-1216 along with panels BO-1218. Install one side panel on each side with one corresponding ceiling panel or you will most likely have problems installing. *See figure 5.*

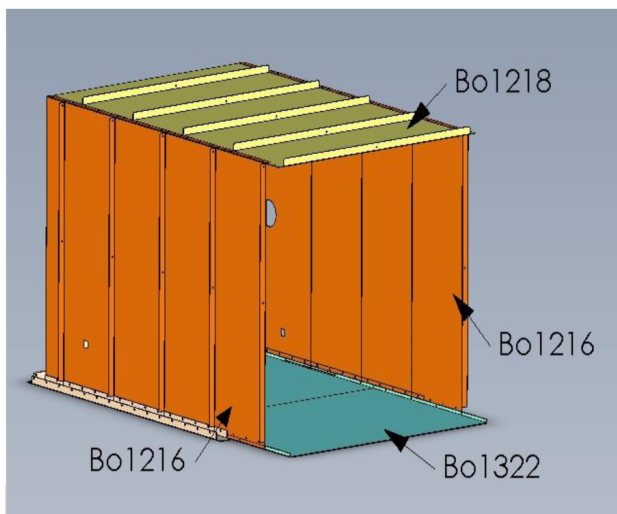
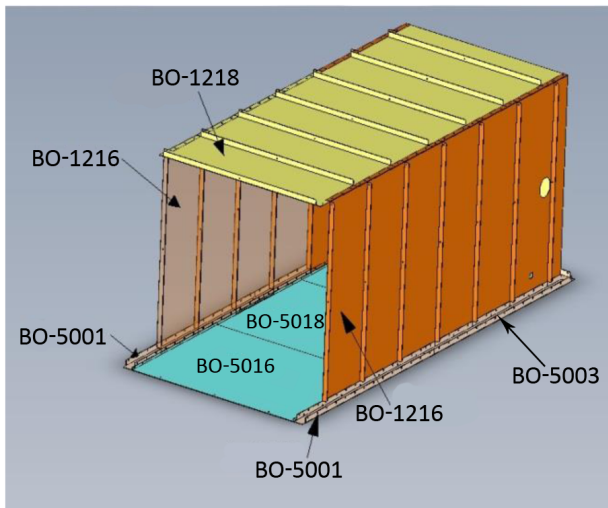

Figure 6

6) Lay out part BO-1322. *See figure 6.*



7) Install parts BO-5003 (right), BO-5001 (right), BO-5016, BO-5001 (left) and BO-5003 (left).
Shown in figure 7.

Figure 7

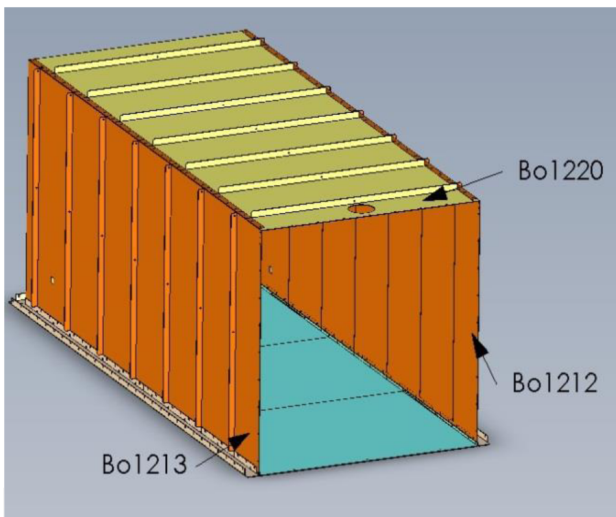

8) Install panels BO-1213, BO-1220 and BO-1212 as shown in **figure 8**.

Figure 8

Installing 2" insulation) After assembling the inside panels (steps 1-8), install one layer of the supplied 2" insulation on both sides and the back of the oven. Before installing the outside panels, cut insulation to size and apply to each panel as they are installed.

Before installing the roof panels, install two layers of insulation to the oven then install the roof panels.

Install two layers of insulation inside of the doors as well, before installing the door panels.

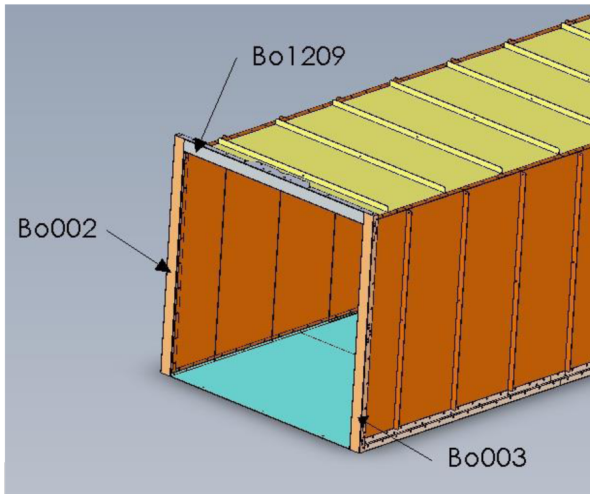

Figure 9

9) Now install parts BO-002, BO-1209 and BO-003 using 5/16" bolts. **See figure 9.**

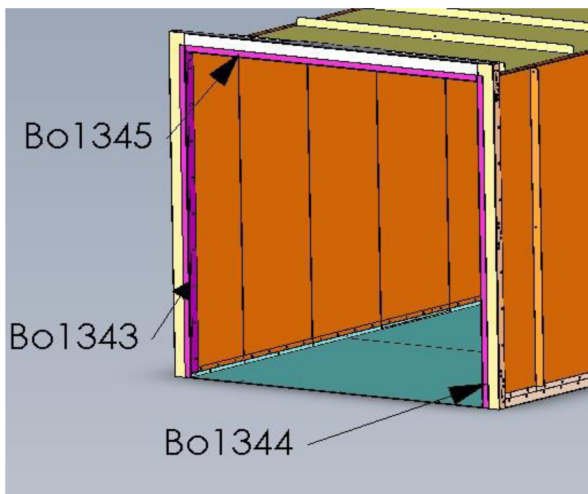

Figure 10

10) Install seal bracket BO-1343, BO-1345 and BO-1344 using 5/16" bolts. **See figure 10.**

Now you can tighten all of the bolts on the INSIDE of the oven

11) Bolt panels BO-1240 and BO-013 to bracket BO-008 for both sides of the oven using 5/16" bolts. **DO NOT** tighten bolts yet for adjustments of other panels. **See figures 11 & 12.**

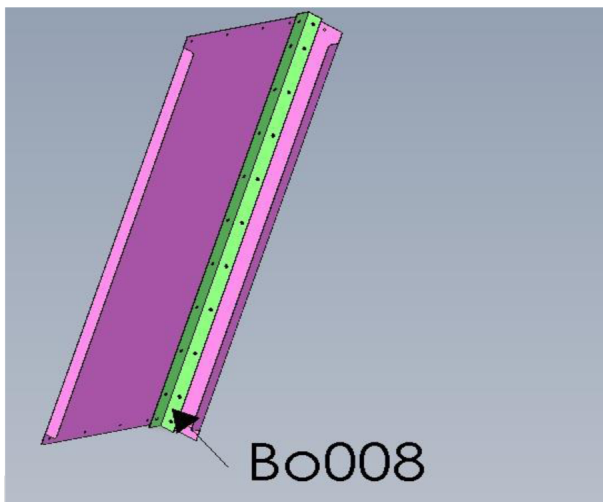

Figure 11

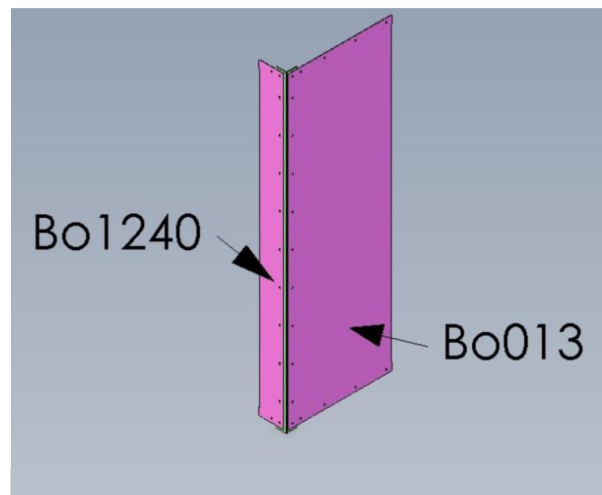
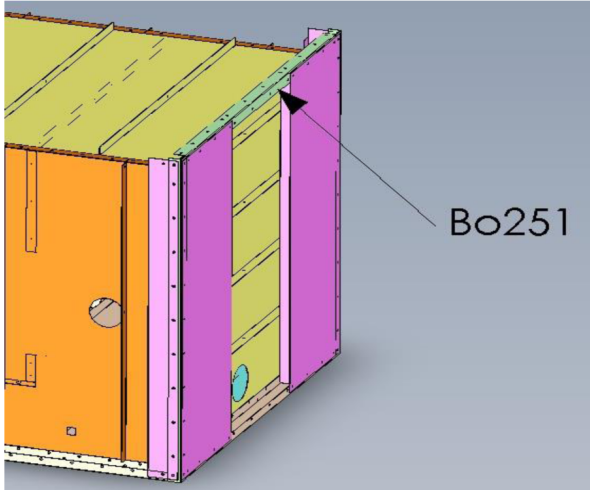
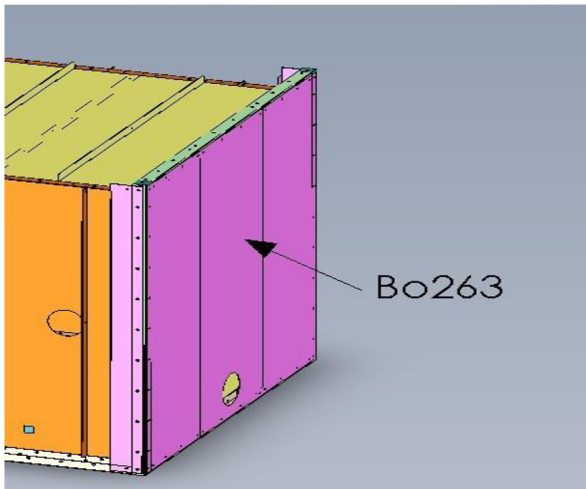

Figure 12



12) Now you can bolt on part B0-251 to the back of the oven. *See figure 13.*

Figure 13



13) Install panel B0-263 with supplied bolts. *See figure 14.*

Figure 14

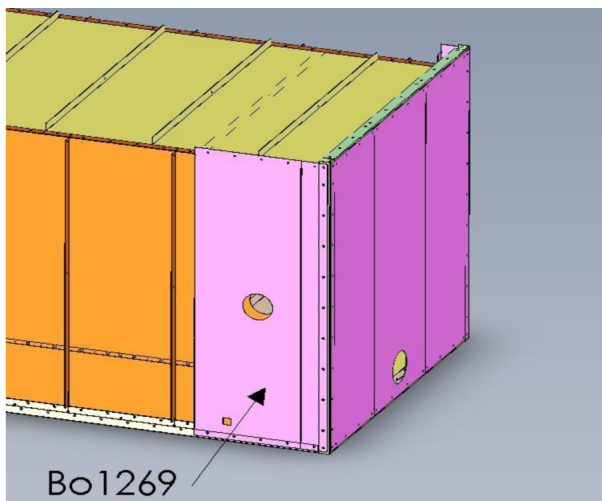

14) Install side panel B0-1269 (*side panel with burner hole*) on the right side of oven. *See figure 15.*

Figure 15

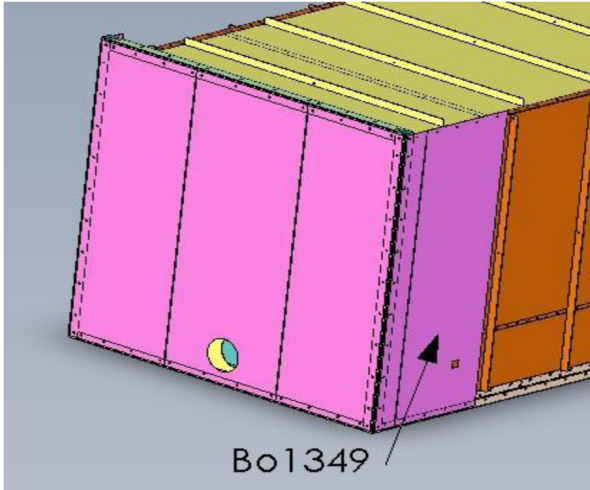

Figure 16

15) Install panel BO-1349 (*side panel with shaft hole*) on the left side of the oven. **DO NOT** tighten bolts until other panels are installed for adjustment. **See figure 16.**

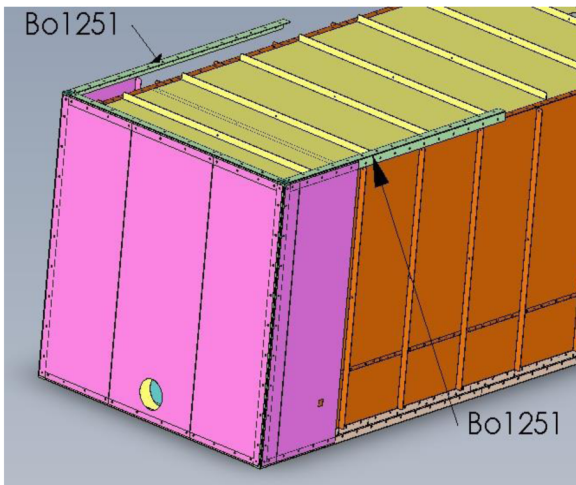

Figure 17

16) Now install BO-1251 on both sides of your oven. **See figure 17.**

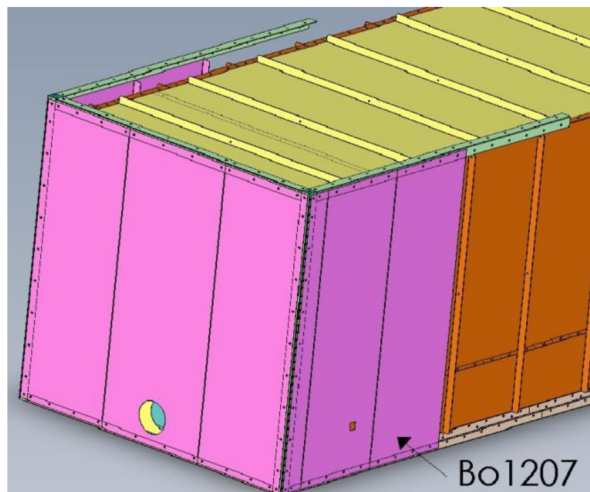

Figure 18

17) Start installing panels BO-1207 on both sides of the oven. **See figure 18.**

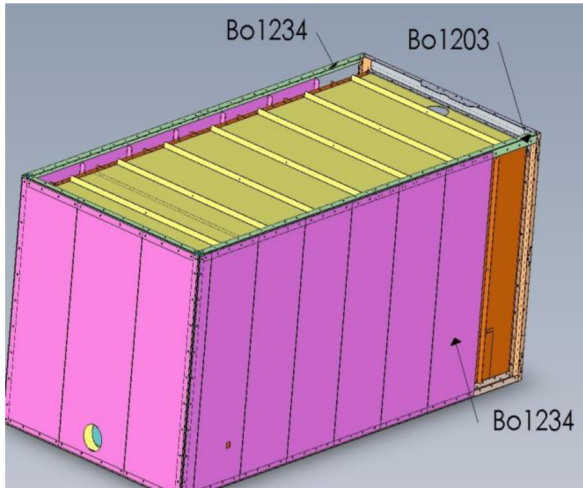

Figure 19

18) Once you get to the third panel, install BO-1234 as show in **figure 19**. Now continue installing panels BO-1207.

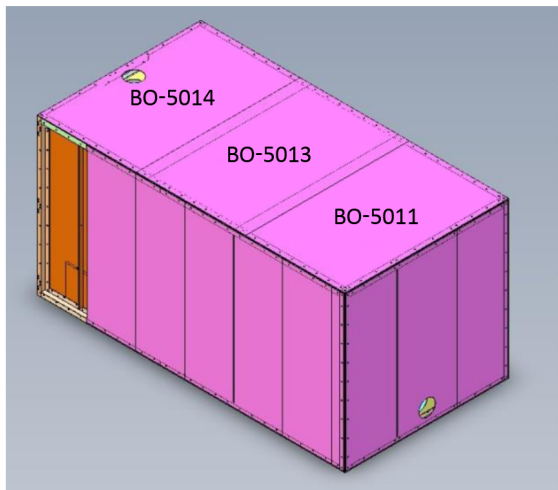

Figure 20

19) Install top panels BO-5014, BO-5013 and BO-5011 in the order that they appear starting with panel BO-5014. Each panel will overlap the other by a few inches. **See figure 20.**

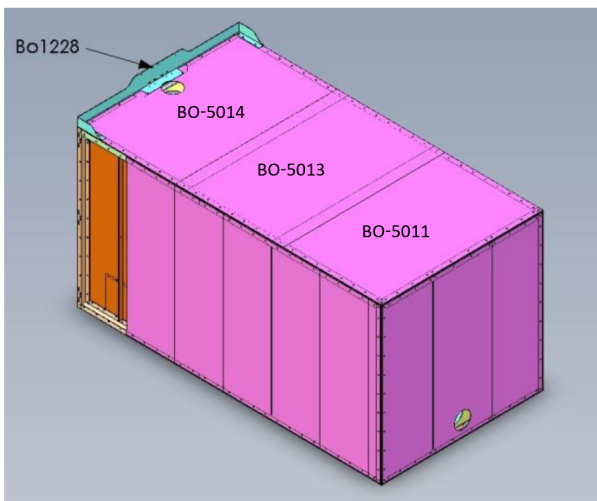

Figure 21

20) Now bolt BO-1221 to the top of the oven. **See figure 21.**

Now tighten ALL of the bolts on the outside and top of the oven.

21) Install parts BO-029A, BO-0011, BO-027 and hinge on both sides of the oven. Make sure not to tighten bolts so the door can be adjusted. *See figures 22 - 25.*

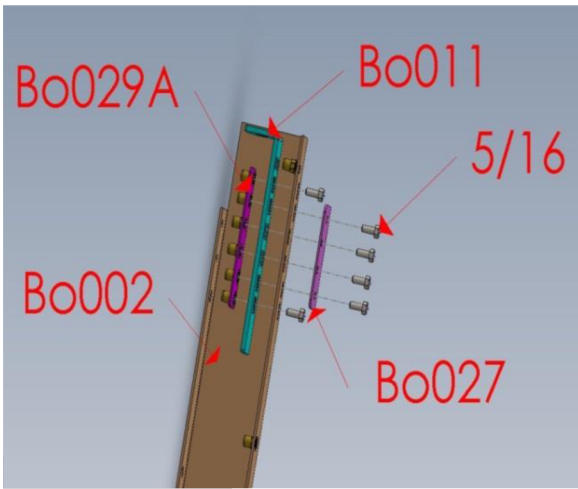

Figure 22

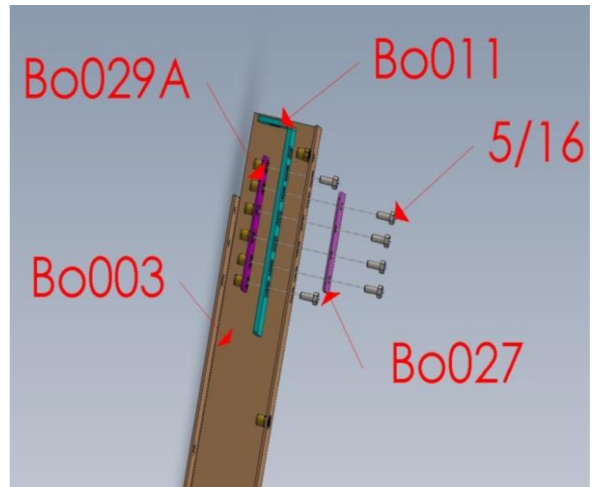

Figure 23

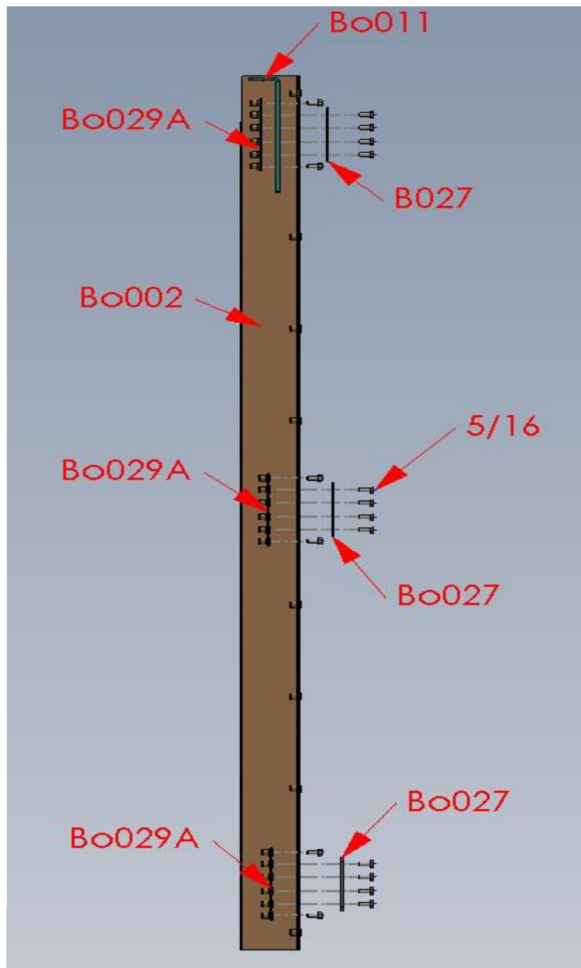

Figure 24

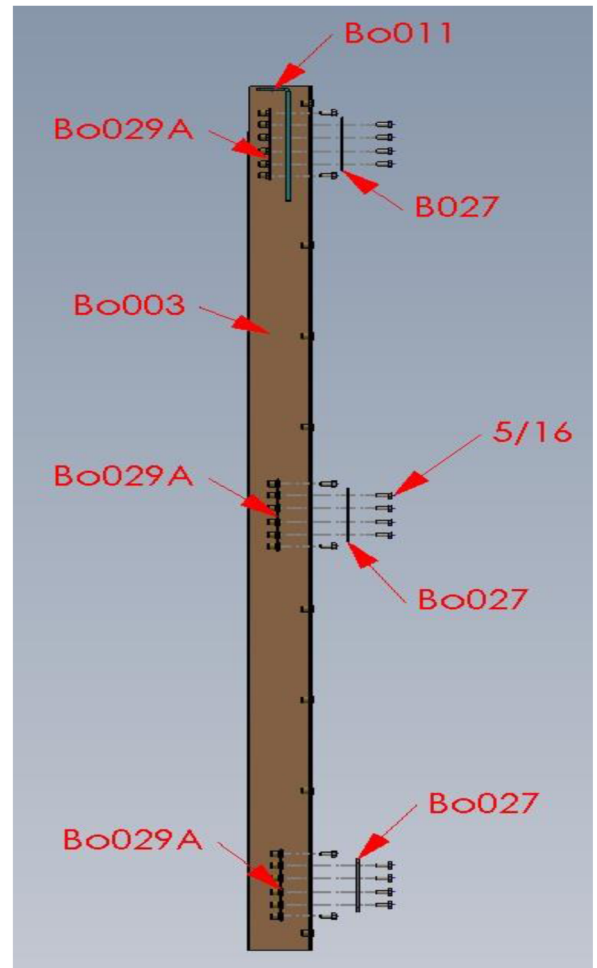

Figure 25

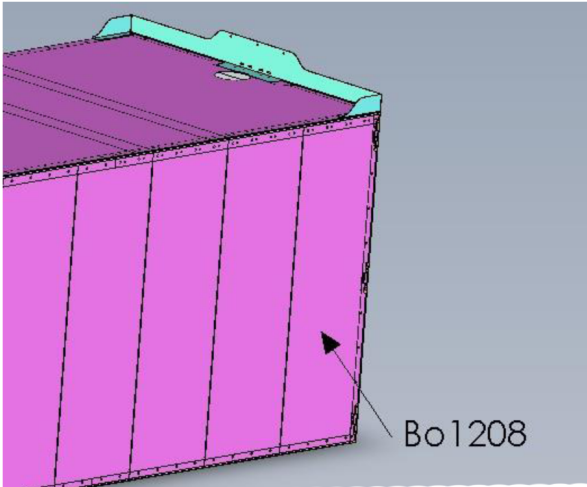

Figure 26

22) Install panels BO-1208 on both sides of oven. *See figure 26.*

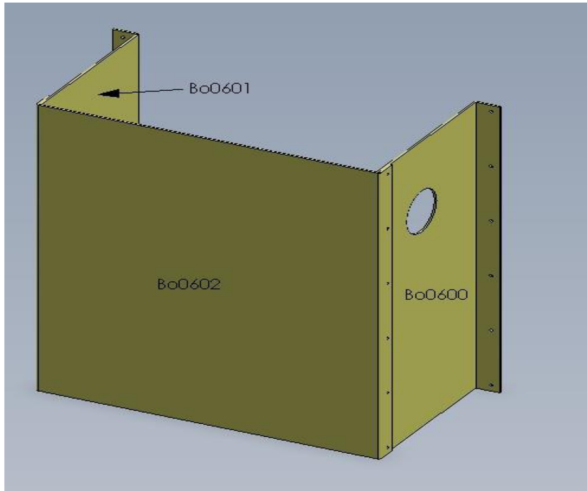

Figure 27

23) Assemble parts BO-0600, BO-0601 and BO-0602. *See figure 27.* Install burner box to the back of the oven; center it up to the oven.

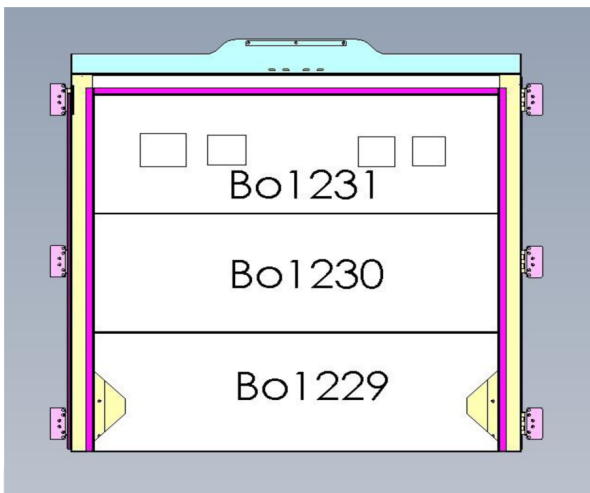
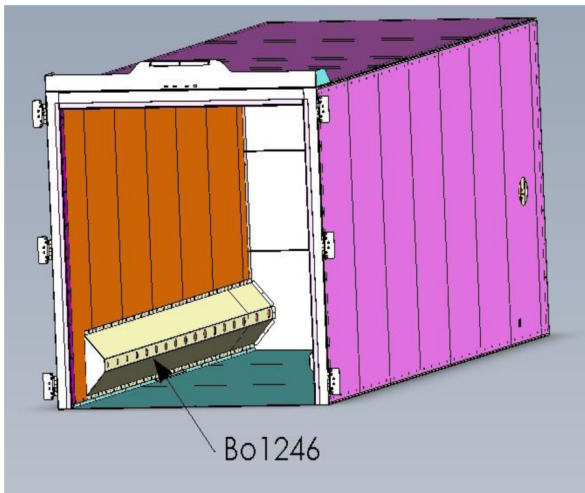

Figure 28

24) Install panels BO-1229, BO-1230 and BO-1231 as shown in *figure 28*. Install 22" from the back wall of the oven using zip screws.



25) Install the air duct BO-1246 on both sides of the oven using 5/16" bolts on the bottom and zip screws on the top. *See figure 29.*

Figure 29

26) Finally, install the doors. Start all of the bolts, but don't tighten until the doors have been properly adjusted. *See figure 30.*

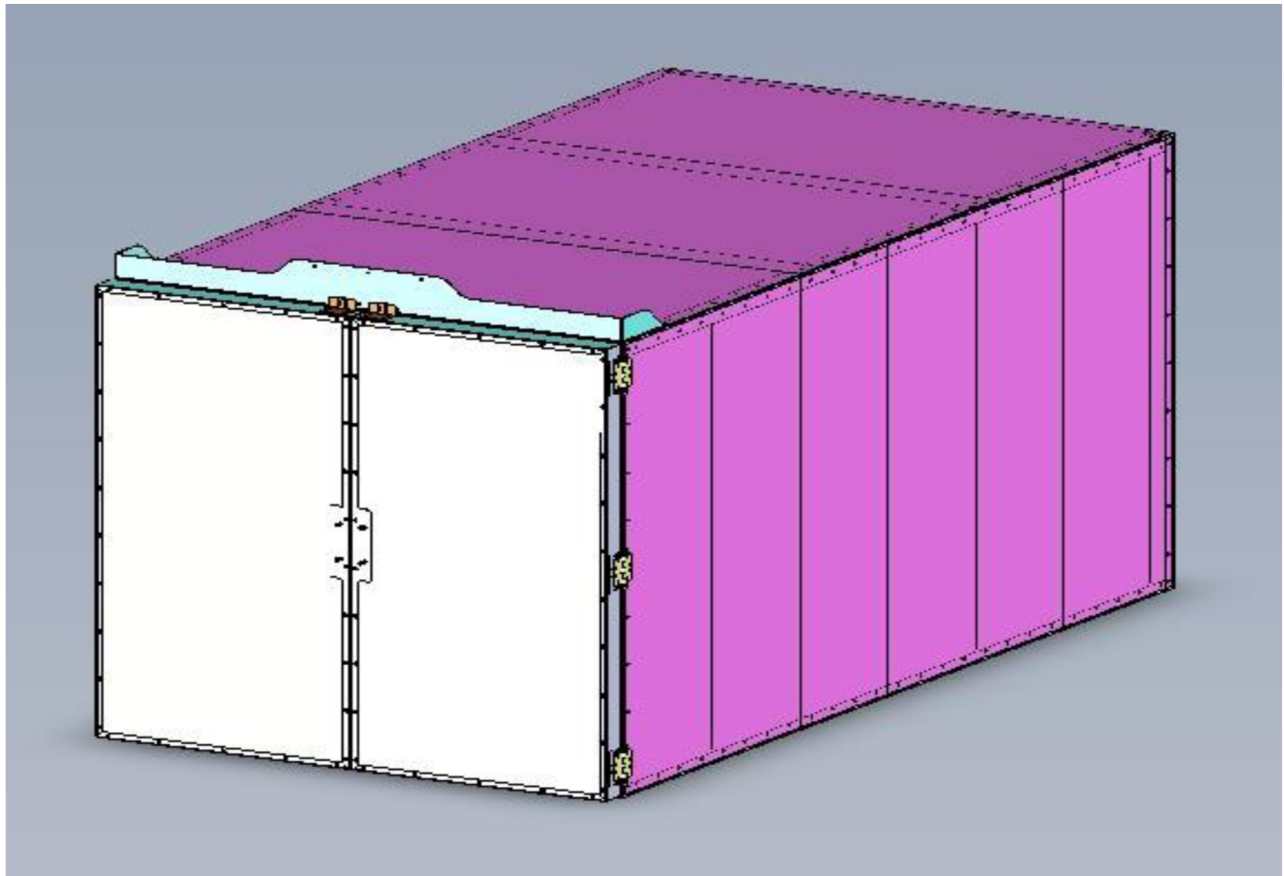

DUCT WORK

(NOTE: Check with your local code enforcement for all safety codes in your location.)



FRESH AIR INTAKE



EXHAUST DUCT

The fresh air intake is located at the center of the back wall. Install the ductwork before installing partition wall and burner. Attach part B to Part BO-1470-2, insert parts into back panel and attach BO-1470-2 to back panel with the supplied 5/16 self-tapping screws. Part C should be installed into part A, then attach part A to part B.

Exhaust duct is located in front of the oven on top. Install ductwork using the same steps as the fresh air intake.

Fresh air can be brought in from either inside or outside of your building.

Exhaust duct will need to be exhausted out of the building.

Start oven with the Intake/Exhaust duct dampener at $\frac{1}{2}$ way position. Adjust accordingly for better heat up time.

BURNER ASSEMBLY

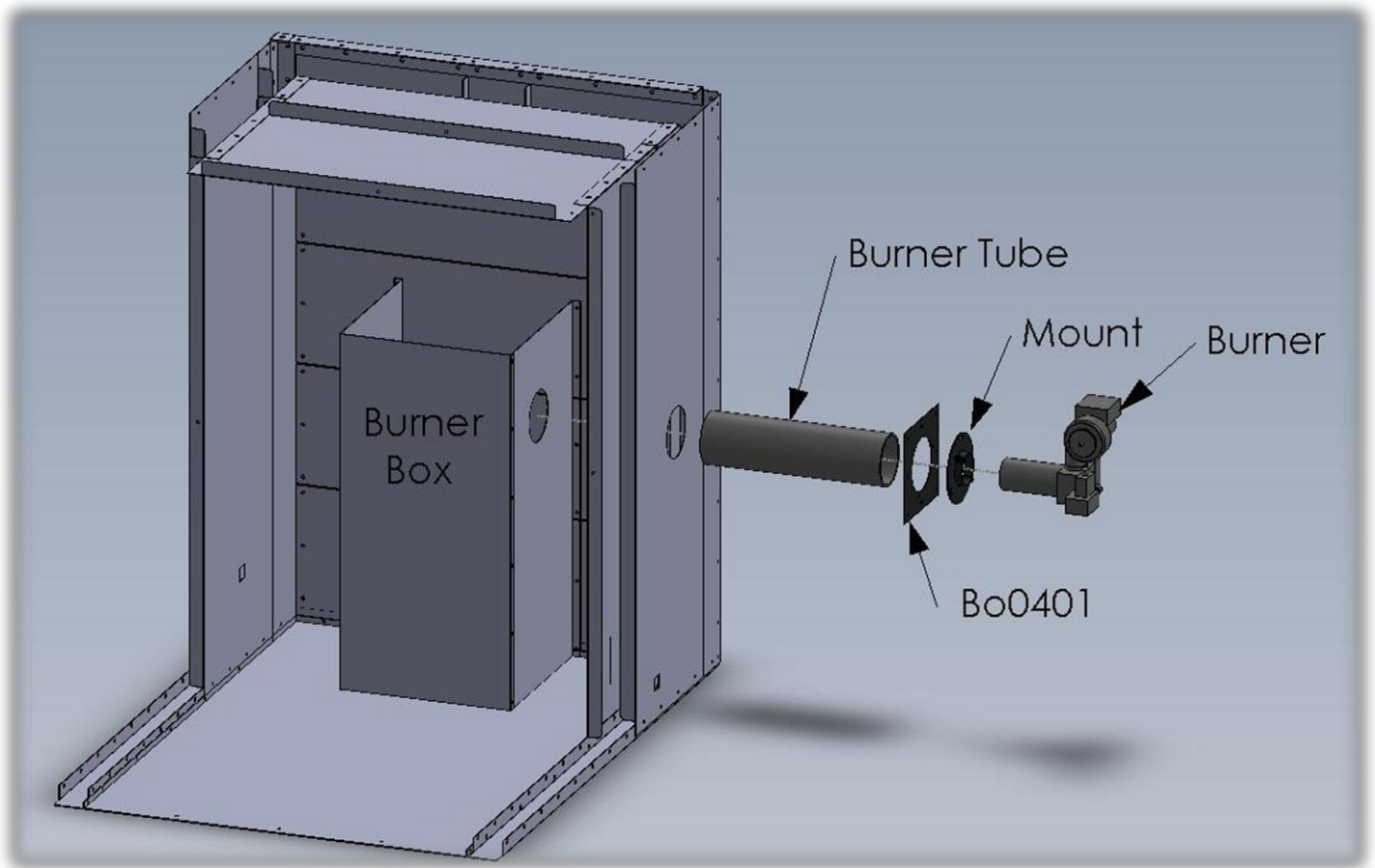

1. Insert burner tube through the side panel and burner box.
2. Attach BO-0401 to the side of the oven using eight (8) of the supplied self-tapping bolts.
3. Bolt the burner mount to BO-0401 using three (3) self-tapping bolts. Line the mount up with the 3 holes already in BO-0401.
4. Now install the burner approximately 3-4 inches inside of the burner tube then tighten the clamp bolts.

(NOTE:

- 1. Always have a professional install all gas lines. Failure to do so may result in property, equipment or personal injuries and may void any warranty on equipment.*
- 2. Make sure to not over tighten the self-tapping bolts to avoid stripping.*
- 3. Once again make sure to only install burner 3-4 inches in for proper use.)*

FAN ASSEMBLY

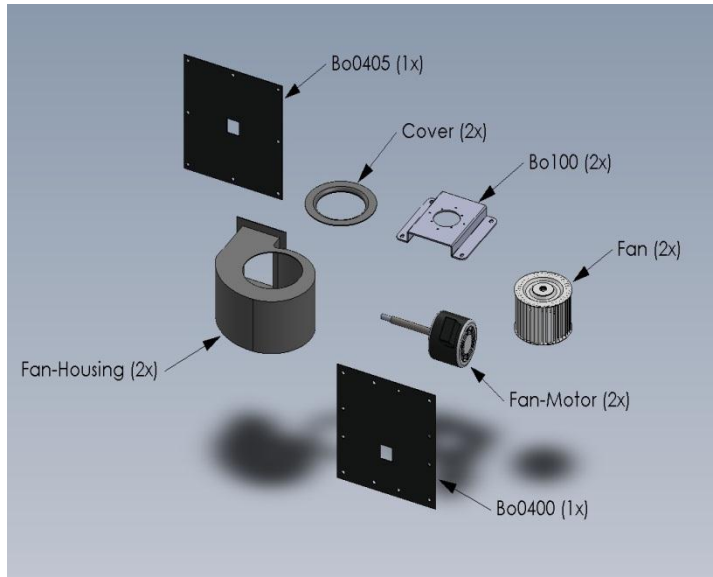

1. Attach part BO-0400 to BO-1269 on the right side of your oven, and attach BO-0405 to BO-1349 on the left side using the supplied self-tapping screws. *(NOTE: Make sure cutouts are lined up before tightening any screws.)*

2. Attach the fan housing to the inside panels BO-1350 and BO-1268. *(NOTE: Newer ovens will have slots cut for the lip on the housing to slide in for easier installation.)*

3. Using the supplied screws, attach the fan motor to BO-100 for both sides. Then, slide the shaft into the hole and line it up with the fan housing then using the self-tapping

screws, attach BO-100 to the side of the oven. *(NOTE: Make sure not to tighten the bolts until the fan is installed.*

4. Now install the fan onto the shaft. Spin the shaft by hand to make sure there isn't any interference. If all clear, tighten the bolts for BO-100.

5. Finally, tighten the set-screw for the fan and install the cover.

REPEAT STEPS 3 – 5 for the left side of the oven.

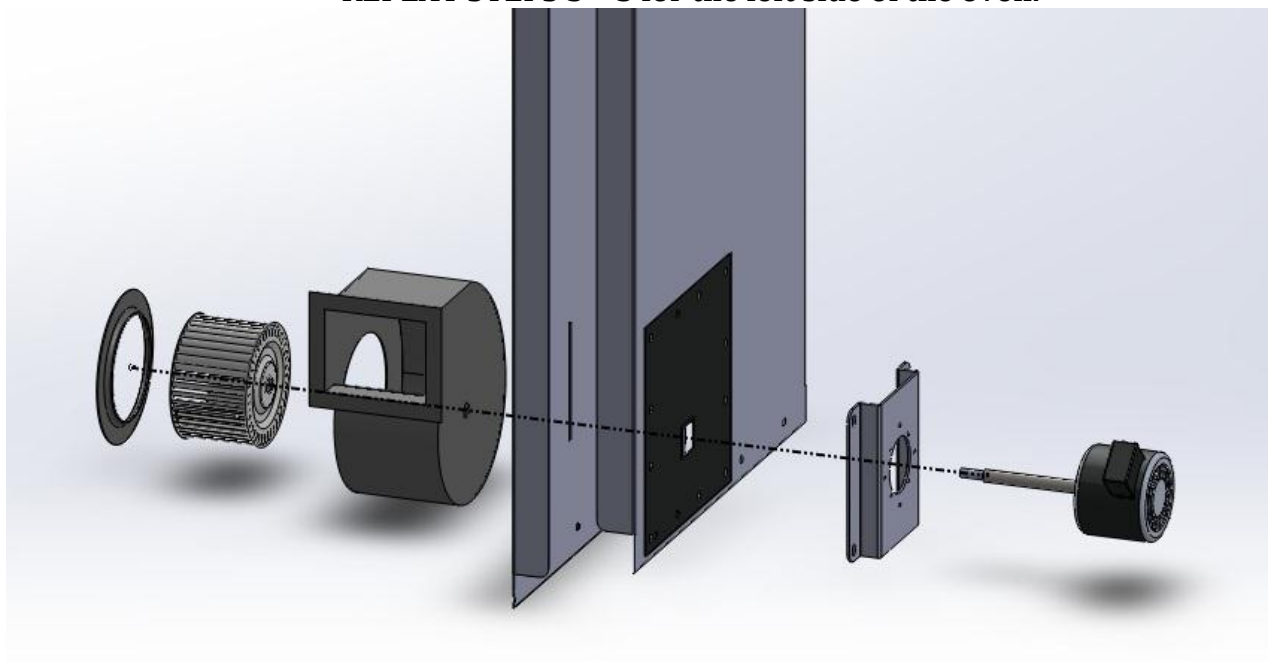

STARTING OVEN

1. Turn the main power on. This will feed power to the blower and PID. *(NOTE: If no power, check the timer to make sure it didn't trip.)*
2. Turn gas on. Make sure there are no gas leaks.
3. Set your temperature on PID to desired setting. (385° – 400°)
4. Turn burner switch on, let the line purge and the burner should kick on within 30 – 60 seconds.
5. Let the oven temperature rise to the set temperature and the burner will shut off. The oven is now ready to use.

SHUTTING DOWN OVEN

1. Turn the burner switch off.
2. Let the oven cool down to at least 125°F before turning off the main power, this gives the fans time to cool. *(NOTE: Failure to do so will destroy the fans and void any and all warranties on the blower(s).)*
3. Once cooled down to 125°F, shut off the main power.

TIMER

1. The timer on the control panel is for emergency shutdown only! This timer should be preset to "hours". Set timer between 8 – 10 hours or your regular shift time. *(NOTE: Part timers are sold separately.)*

ADJUSTING DOORS AND DOOR SEAL

- Get oven into the exact place you want it before setting doors. Slight variations in the surface where oven is placed can and will affect the alignment of the oven doors. Ideally you want a level spot to put your oven but this almost never the case, so this is to help you compensate for you floor.
- Open the door on your oven
- Place a large screwdriver or pry bar under the door you are going to adjust
- Using a ½” wrench, socket, or other type of tool loosen the bolts attaching the hinges to the oven only (*NOTE: see illustration on next page*). Loosen the bolts only do not remove these bolts. You must also loosen the bolt above and below each hinge. Do not loosen any of the bolts attaching the hinges to the door at this time. The bolts holding the hinge to the oven adjust the doors up and down. The bolts attaching the hinges to the doors are used to adjust the door in and out.
- Once the bolts are all loose you may slide door up and down to align doors.
- If your floor is very unlevelled you may need to put shims under the rear of the oven either on the right or left side to bring doors into alignment. This will not affect the oven at all.
- After you have adjusted the oven to your shop floor tighten all the bolts up.
- Now you are ready to adjust the doors so they seal properly. With the doors unlatched loosen the bolts on the door on and around hinges much like you did adjusting up and down.
- Slide door all the way in while open.
- Close doors and latch, this will bring the door out to the seal.
- Tighten all bolts.
- Have someone close doors while you are inside and look for areas where door seal is not touching door and making a good seal.
- The bolts holding the door seal to the oven can be loosened allowing the door seal to slide out to the oven in areas where a better seal is needed.
- Retighten all bolts when done.



USING A 1/2" WRENCH/SOCKET,
LOOSEN THE BOLTS IN ALL OF THE
HINGES TO ADJUST THE DOORS.

TROUBLESHOOTING

MAIN POWER	
No power when main power is "ON"	<ul style="list-style-type: none"> • Check the fuse in the black fuse holder inside of the control box. • Verify 110v AC power is available to the box. • Refer to wiring diagram to verify connections are correct. • Verify that E-Stop is in the "OUT" position.
BURNER	
Fans do not start when the main power is on.	<ul style="list-style-type: none"> • Refer to the wiring diagram and check ALL connections
Burner(s) fail to engage.	<ul style="list-style-type: none"> • Verify that the burner switch is set to "ON". • Verify that the timer is set to "hours" and that the green light is flashing on the timer. If a red light is on, you need to reset the timer. • Verify that your set temperature of the oven is higher than your actual temperature reading inside of the oven. • Refer to wiring diagram to verify connections.
Burner fails to ignite once engaged.	<ul style="list-style-type: none"> • Verify that the burner is no more that 3 inches inside of the oven. There should be 6 inches of black burner tubing on the outside of the burner mount. • Verify that the position of the dampner on the side of the burner is no more than 2 inches from the fan. • Check gas supply and verify that the correct pressure is available to the burner. • Purge the gas lines. (If the burner is natural gas, also ample time for the gas to reach the burner. The presence of a gas smell doesn't mean that the air has been purged from the line.)
PID	
PID is not functioning properly.	<ul style="list-style-type: none"> • The PID comes preset, however in some instances due to power surges or other reasons, the PID may need to be reset. Refer to the "PROGRAMMING THE PID" section of this manual and follow the step-by-step instructions on resetting to default.
RESETTING THE PID	
<p>After resetting the PID to default, press "set" for 3 seconds. Use the gray button to find "CnPT" then use the arrows to find "J" and press "set". Again, press "set" for 3 seconds and use the gray button to find "tPUn" then use the arrows to change the value to "F". Press "set". Press "set" for 3 seconds again and use the gray button to find "Cntrl" and use the arrows to change the parameter to [onof]. This should have reset your PID.</p>	

Columbia Coatings Kool Kure Oven Wiring Diagram

TEMPERATURE CONTROLLER (PID)
SL4848-RR (SOLO)

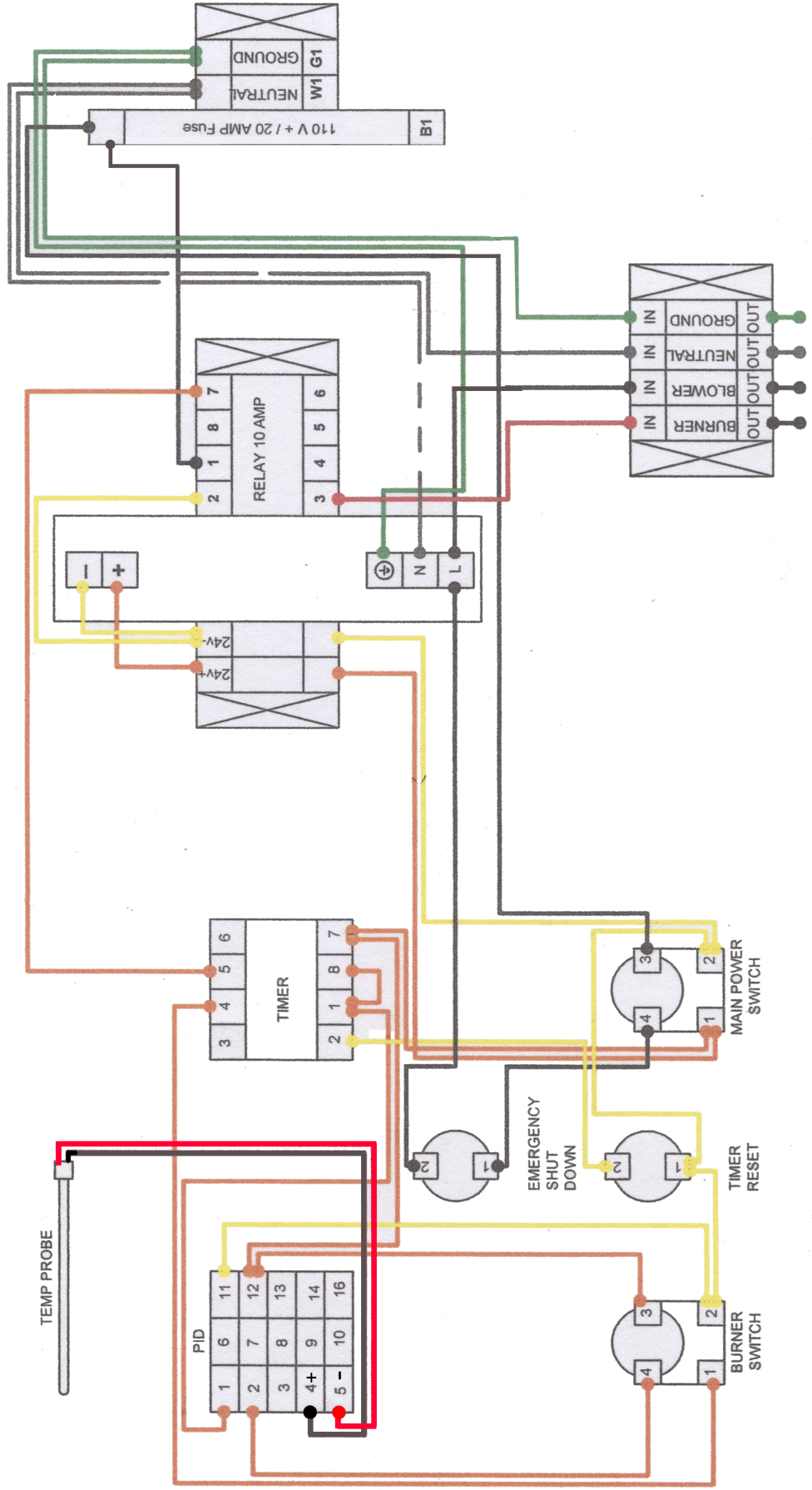



Kool Koat[®]
KOOL KURE[®]
OVEN & BOOTH SYSTEMS

[*P250 BURNER ORIFICE SIZING MANUAL*]

This manual is for informational purposes only. When working with flammable gases it is always best to have a licensed professional make all connections and check for leaks. Columbia Coatings is not responsible for damage to either person or property resulting from improper use or maintenance of the gas burner. Please refer to burner manual for proper gas settings.

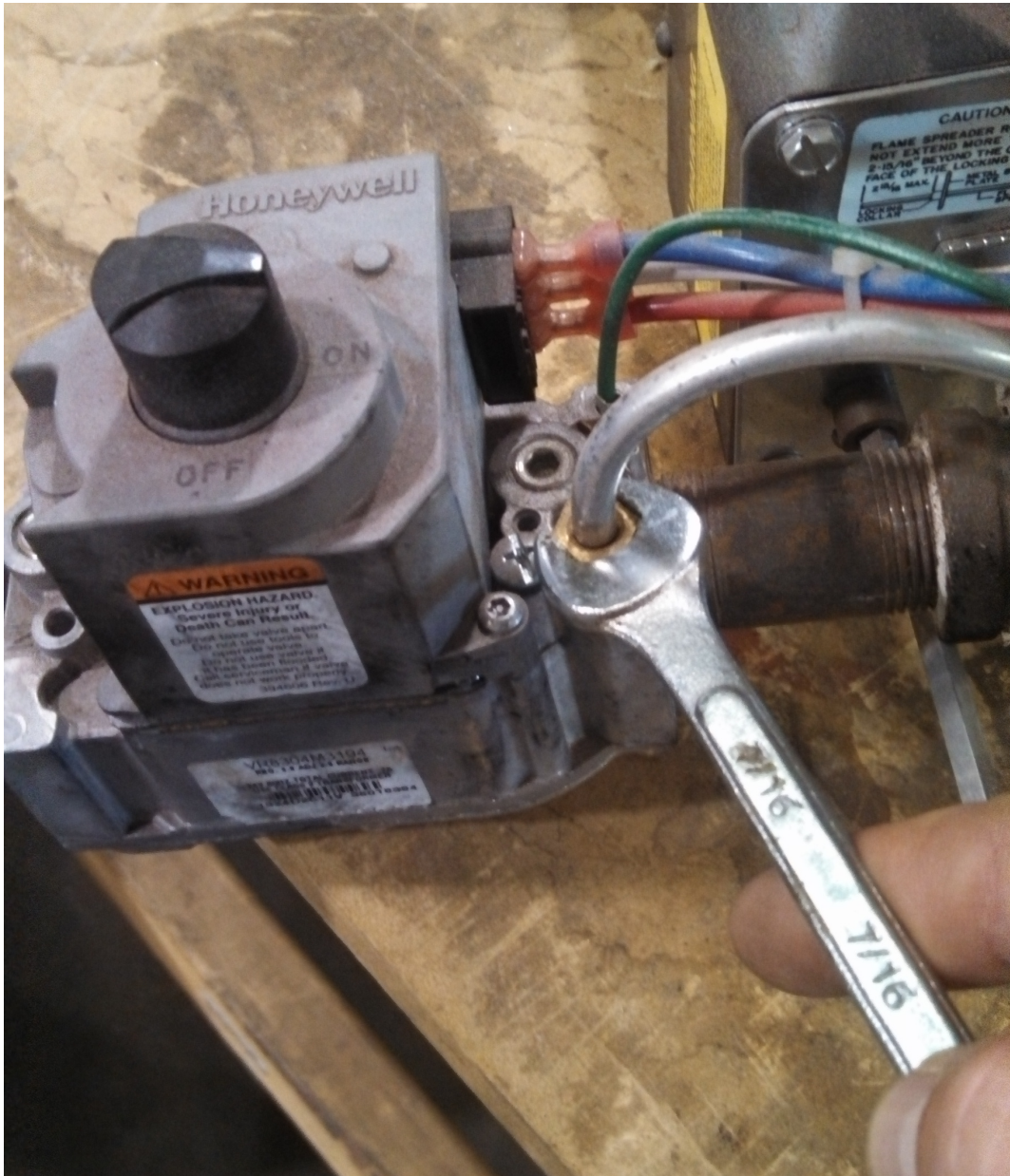

IMAGE 1

REMOVE GAS PRESSURE LINE FROM VALVE USING 7/16" WRENCH. IT IS NOT NECESSARY TO REMOVE LINE FROM BURNER, ONLY FROM VALVE.

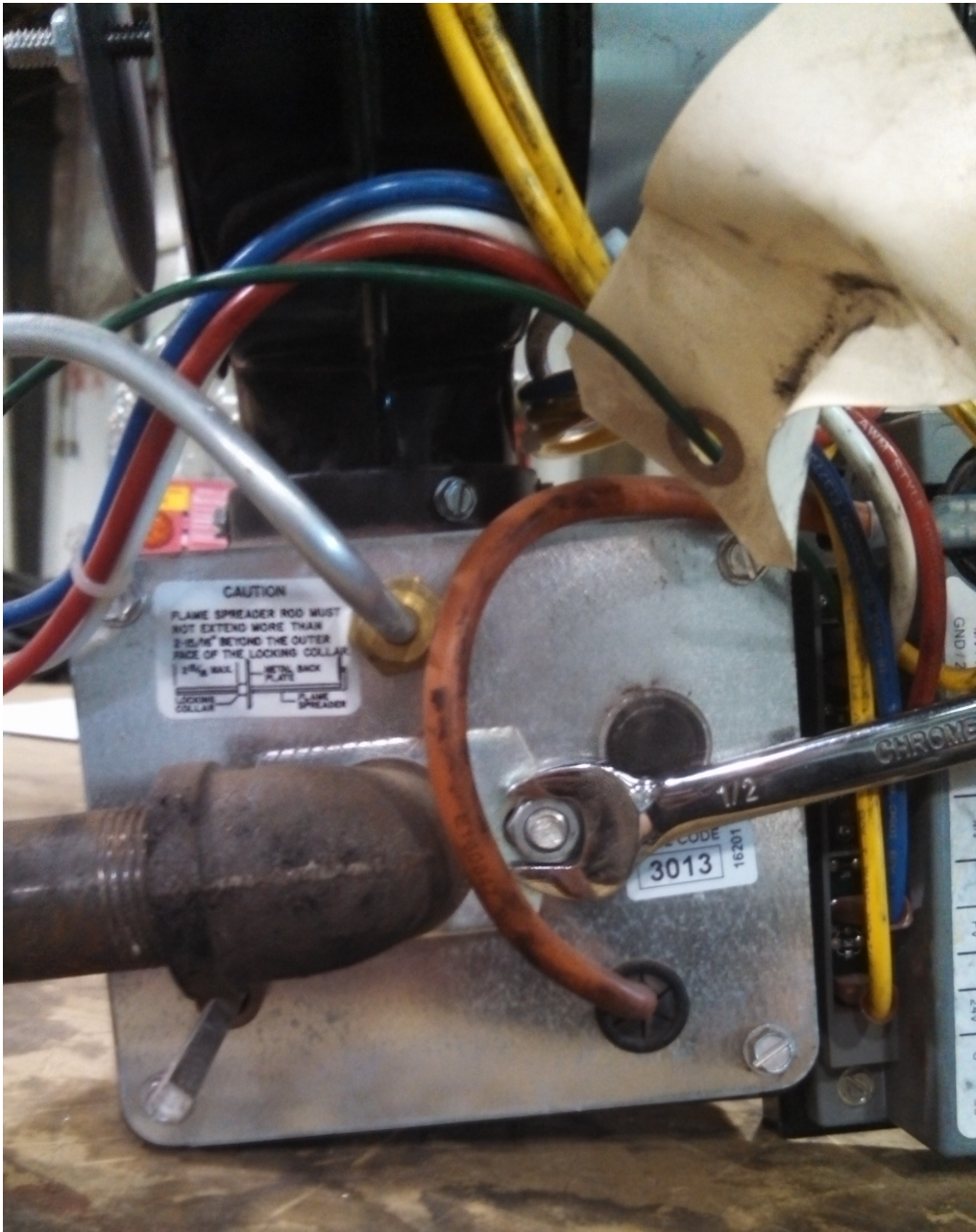

IMAGE 2

NEXT, USING $\frac{1}{2}$ " WRENCH REMOVE NUTS HOLDING VALVE TO BURNER. THIS IS LOCATED ON THE REAR OF THE BURNER AS SHOWN IN IMAGE 2.



IMAGE 3

AFTER REMOVING THE VALVE FROM THE BURNER YOU WILL SEE THE ORIFACE LOCATED AT THE END OF THE VALVE TUBING. REMOVE THE ORFICE BY TURNING COUNTER CLOCKWISE.



IMAGE 4

AS SEEN IN IMAGE 4, THE ORIFACE HAS BEEN REMOVED AND IS READY TO BE DRILLED TO NEW SIZE. YOU WILL NEED TO PLACE ORIFACE FLAT SIDE UP IN A VISE TO DRILL OUT THE ORIFACE.

B.T.U. (kW) INPUT PER HOUR	NATURAL GAS 3 1/2" (871.8Pa) W.C.P.	PROPANE GAS 10" (2491 Pa) W.C.P.
	Drill Size	Drill Size
50,000 (14.65)	#30 (.128") (3.264mm)	#45 (.082") (2.083mm)
75,000 (21.98)	5/32 (.156") (3.967mm)	#41 (.096") (2.438mm)
90,000 (26.38)	#17 (.173") (4.394mm)	#37 (.104") (2.642mm)
100,000 (29.31)	#14 (.182") (4.623mm)	#35 (.110") (2.794mm)
125,000 (36.63)	#5 (.205") (5.22mm)	1/8 (.125") (3.175mm)
130,000 (38.1)	#4 (.209") (5.309mm)	#30 (.128") (3.264mm)
150,000 (43.96)	#1 (.228") (5.791mm)	#29 (.136") (3.454mm)
160,000 (46.89)	15/64 (.234") (5.954mm)	#28 (.140") (3.569mm)
175,000 (51.29)	C (.242") (6.147mm)	#26 (.147") (3.734mm)
180,000 (52.75)	1/4 (.250") (6.35mm)	#25 (.149") (3.797mm)
200,000 (58.61)	G (.261") (6.629mm)	#22 (.157") (3.988mm)
225,000 (65.94)	J (.272") (7.036mm)	#19 (.166") (4.216mm)
242,000 (70.92)	L (.290") (7.366mm)	#17 (.173") (4.394mm)
250,000 (73.27)	M (.295") (7.493mm)	#16 (.177") (4.496mm)

IMAGE 5

THE ABOVE CHART WILL TELL YOU THE CORRECT DRILL BIT SIZE FOR THE DESIRED BTU OUTPUT.

EXAMPLE: 175,000 BTU IN NATURAL GAS REQUIRES A .242" DRILL BIT OR 6.35mm. FOR PROPANE THE SAME BTU OUTPUT WOULD REQUIRE A .147" DRILL BIT OR 3.734mm.

SOME DRILL BIT SETS ARE ALSO SIZED BY LETTERS AND NUMBERS, THESE SIZES ARE ALSO INCLUDED IN THE CHART.

Oven Size	BTU	Natural Gas Orifice Drill Size	Propane Orifice Drill Size
4x4x6	160,000	15/64 (.234)	(.14)
6x4x6	180,000	1/4 (.250)	(.149)
6x4x8	180,000	1/4 (.250)	(.149)
6x6x6	200,000	(.261)	(.157)
6x6x8	200,000	(.261)	(.157)
6x6x10	225,000	(.272)	(.166)
6x6x12	250,000	(.295)	(.177)
8x8x8	250,000	(.295)	(.177)
8x8x10	295,000 (4" Manifold Pressure)	(.281)	(.281)
8x8x12	332,500 (3" Manifold Pressure)	(.332)	(.332)

IMAGE 6

IMAGE 6 WILL TELL YOU THE RECOMMENDED ORIFACE SIZE FOR YOUR OVEN. FIND YOUR OVEN SIZE IN ROW 1, ROW 2 WILL GIVE YOU RECOMMENDED BTU OUTPUT FOR YOUR BURNER BASED ON YOUR OVEN SIZE. ROW 3 AND 4 WILL GIVE DRILL BIT SIZES FOR BOTH NATURAL GAS AND PROPANE.

ATTENTION!!!

BE SURE TO USE THE CORRECT SIZE FOR YOUR GAS TYPE.
ONCE YOU HAVE DRILLED OUT ORIFACE REINSTALL THE ORIFACE AND
FOLLOW INSTRUCTIONS IN REVERSE TO REASSEMBLE BURNER.

A QUALIFIED GAS TECH SHOULD MAKE ALL GAS CONNECTIONS AND
CHECK FOR LEAKS BEFORE BURNER IS REFIRED. NEVER HOOK
UNREGULATED GAS LINE TO THE BURNER, AS DAMAGE TO BURNER
WILL RESULT. A PROPERLY RATED REGULATOR FOR CORRECT WC AND
PSI MUST BE IN LINE BEFORE BURNER. CONTACT A CERTIFIED GAS
TECH FOR PROPER REGULATOR SIZING.

For oven tech support call Columbia Coatings
Tel: 1-800-974-5022 or (931) 388-7730

For Tech Support on burner you may also contact Wayne
Combustion Systems.
Tel: 1-800-443-4625 or 1-855-WAYNECS

Email :

Sales@columbiacoatings.com

Chris@columbiacoatings.com

We greatly appreciate your business and want you to be confident in your decision
to purchase our system.

Check us out on Facebook and on the web at www.columbiacoatings.com